

16-BIT LOAD CELL/DUAL STATUS INPUT

16-BIT LOAD CELL/DUAL STATUS

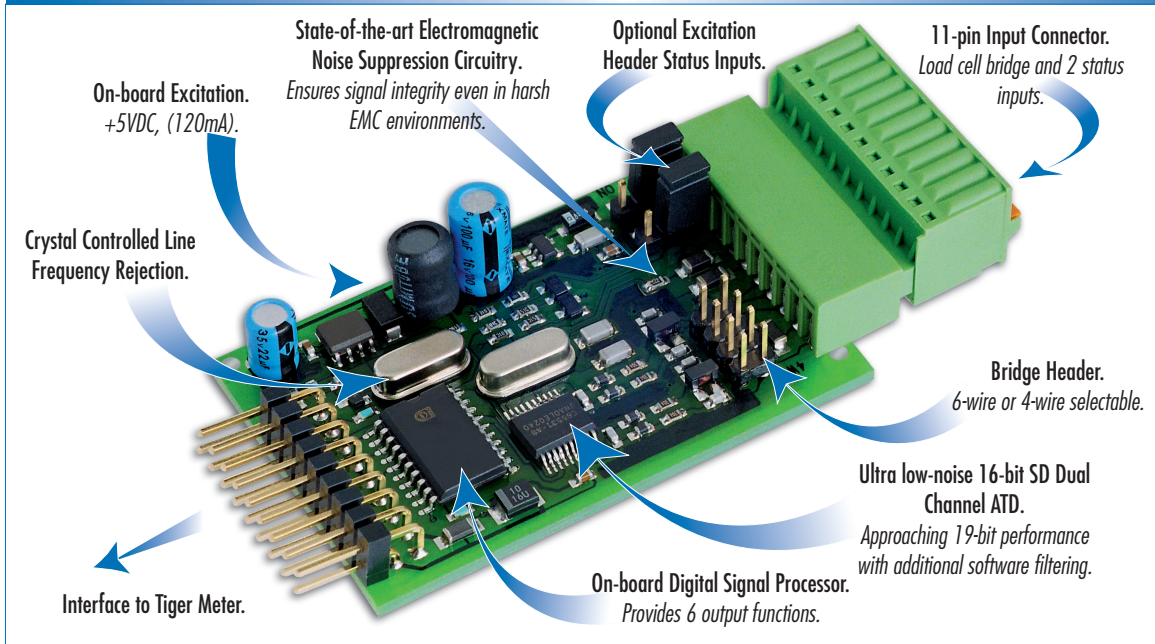

High performance load cell controller with dual status inputs.

Now available in Texmate's family of intelligent load cell input modules is the ISSC 50 Hz and the ISSD 60 Hz input module. With additional dual status inputs, standard weighing tasks can now utilize external control signals. When combined with the Tiger 320 Series controller, a versatile and interactive control system is now possible. For example, a continuous belt weigher with an encoder speed sensor.

Input Module Order Code Suffix

ISSC (50 Hz Rejection)

ISSD (60 Hz Rejection)



Hardware Module Specifications	
Dual Status Inputs	
D1 and D2	Configured as frequency inputs on CH1 & CH2 respectively.
Excitation Voltage	+24 V to power external sensors. Voltage transitions 6 to 24 V.
Inputs	Open-collector configuration available (10 K pull-up resistors.)
Load Cell	
Excitation	On CH3 / CH4 +5 V DC, 130 mA maximum.
Input Range	Software selectable 1 mV/V to 20 mV/V.
Input Sensitivity	0.08 μ V/count maximum.
Zero Drift	\pm 40 nV/ $^{\circ}$ C of full scale maximum.
Span Drift	\pm 5 ppm/ $^{\circ}$ C of full scale maximum.
Non-linearity	\pm 0.003% of full scale maximum.
Input Noise	160 nV pp typical at 1 Hz output rate.
Signal Processing Rate	50 Hz maximum, 1 Hz minimum.

Software Module Features	
Dual Status Inputs	
Frequency Ranges	D1 (CH1), choice of 7 ranges. (0.01 Hz to 655.35 kHz). D2 (CH2), choice of 4 ranges. (0.01 Hz to 500 kHz).
Load cell	
Dual Output Rates	Rapid and average response outputs.
Peak & Valley Outputs	Monitoring over and undershoots.
Capture Output	Hardwire signal capture.
Rate of Change Output	Useful for fine tuning reaction times.
Line Frequency Rejection	50/60 Hz selectable.

Some Relevant Tiger 320 Series Operating System Features	
	Auto-zero maintenance.
	Set TARE, reset TARE.
	Setpoint timer functions.
	Setpoint register reset and trigger functions.
	On-demand calibration.

INPUTS

LOAD-CELL PRESSURE

Connector Pinouts

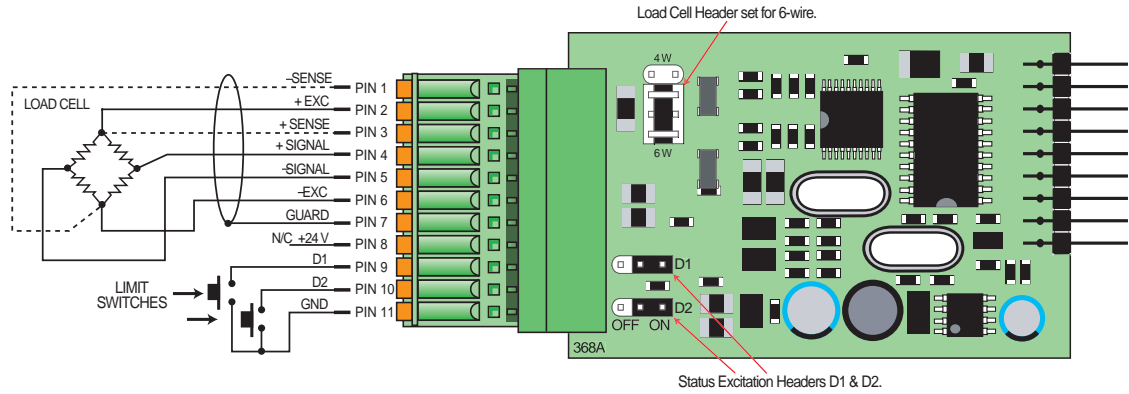

ISSC / ISSD input module showing 6-wire load cell configuration and two status inputs connected to limit switches.

Note:
Both status excitation headers are in the ON position to provide voltage transition from +24 V to 0 V on switch closure. Load cell header selected for 6-wire load cell.

Table 1: ISSC / ISSD 11-pin I/O Connector		
Pin	Description	Function
1	-Sense	Bridge – sense volts
2	+EXC	Bridge + volts excitation
3	+Sense	Bridge + sense volts
4	+Signal	Bridge + signal output
5	-Signal	Bridge – signal output
6	-EXC	Bridge – volt excitation
7	Shield	Cable shield (+2.5 volt)
8	+24 V	Not connected
9	D1	Status input D1 (CH1)
10	D2	Status input D2 (CH2)
11	GND	Common ground

Figure 1 – ISSC / ISSD Configured for 6-wire Load Cell and Two Status Inputs

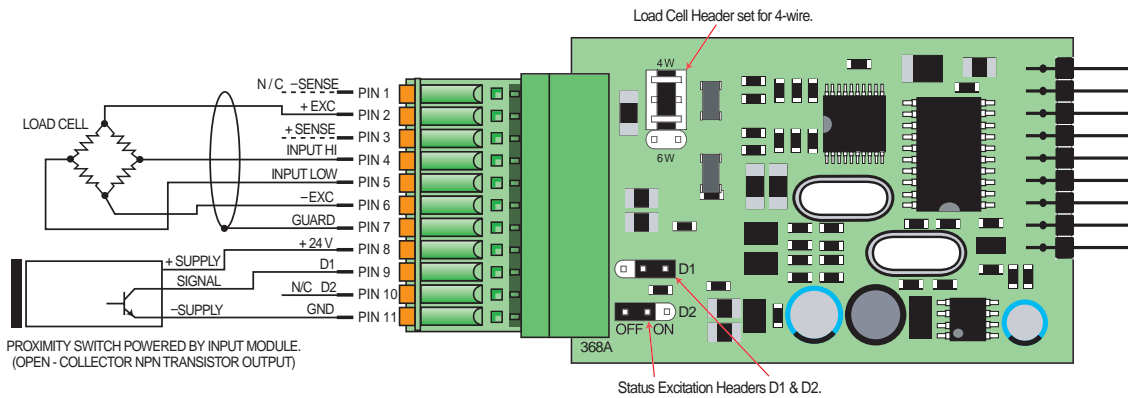

ISSC / ISSD input module showing 4-wire load cell configuration and one status input connected to a proximity switch.

Status input D1 is the signal from an open collector NPN transistor output in a proximity detector. Status excitation header D2 must be in the ON position for the transistor to provide +24 V to GND voltage transitions.

D2 is not connected.

Table 1: ISSC / ISSD 11-pin I/O Connector		
Pin	Description	Function
1	-Sense	Not connected
2	+EXC	Bridge + volts excitation
3	+Sense	Bridge + sense volts
4	Input High	Bridge + signal output
5	Input Low	Bridge – signal output
6	-EXC	Bridge – volt excitation
7	Shield	Cable shield (+2.5 volt)
8	+ 24 V	+ 24 V excitation
9	D1	Status input D1 (CH1)
10	D2	Not connected
11	GND	Common ground

Figure 2 – ISSC / ISSD Configured for 4-wire Load Cell and One Status Input

Technical Description

The load cell input signal is processed in the input module's 16-bit A/D converter and digital signal processor from where it can be fed to either channel 3 (CH3) or channel 4 (CH4) or both. Status input D1 is internally assigned to channel 1 (CH1) and status input D2 is internally assigned to channel 2 (CH2).

CH1 is configured for frequency measurement for D1 in Code 2. CH2 is configured for frequency measurement for D2 in Code 4. Selecting the load cell output for CH3 is configured in Code 5 and for CH4 in Code 6.

The line frequency rejection setting, sensor input range in mV/V, and the output rate are all selected in the smart register 1 (SMT1) menu in Code 2.

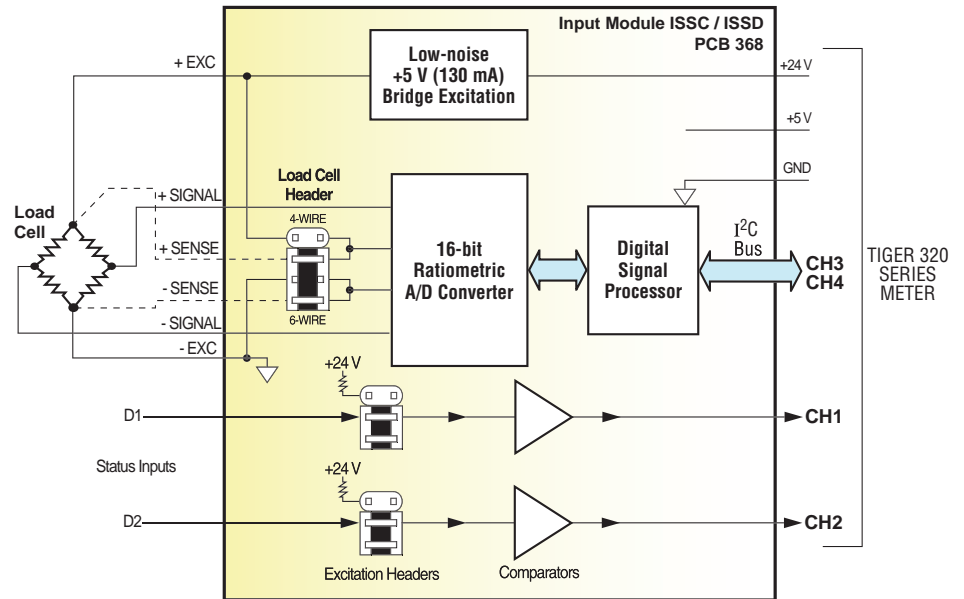

Figure 3 – ISSC / ISSD Signal Flow Diagram

Smart Setup Registers

The Tiger meter uses three smart setup registers to configure all smart input modules. ISSC / ISSD requires only **smart register 1 (SMT1)** to be configured. See Figure 4.

SMT1 configures the load cell input signal for line frequency rejection, input signal range in mV/V, and output rate. SMT1 produces the following six output registers from the load cell input:

- Averaged signal.
- Rapid response signal*.
- Peak signal*.
- Valley signal*.
- Capture signal**.
- Rate-of-change signal.

Note:

* Signal output at the A/D sampling rate.

** Hardware initiated from meter CAPTURE pin.

One of these registers can be transferred to Channel 3 (CH3) via Code 2, the same or another register to CH4 via Code 6.

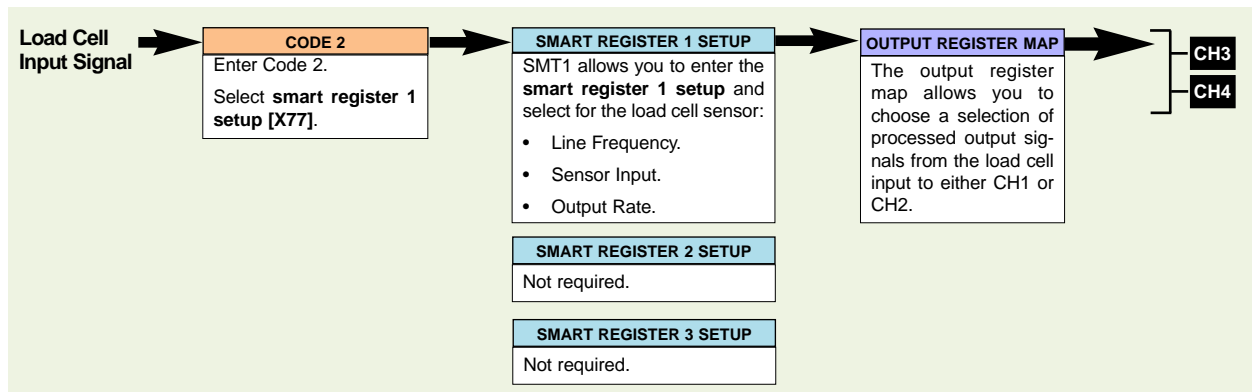

Figure 4 – ISSC / ISSD Smart Setup Register Operational Flow Diagram

The following programming procedures cover all the steps required to configure smart input module ISSC/ISSD:

- Steps 1 to 7:** Code 2 – SMT1 –
 - 1) Line frequency rejection.
 - 2) Signal range in mV/V.
 - 3) Output rate.
- Steps 8 to 9:** Code 2 – CH1 – Frequency range for status input D1.
- Steps 10 to 12:** Code 4 – CH2 – Frequency range for status input D2.
- Steps 13 to 14:** Code 5 – CH3 – Output register for load cell input.
- Steps 15 to 16:** Code 6 – CH4 – Output register for load cell input.

SMT1 Setup

Enter Code 2 and then enter SMT1 to configure line frequency rejection, signal range, and output rate settings.

1 Press the **[P]** and **[↑]** buttons at the same time to enter the main programming mode.

2 Press the **[P]** button three times to enter Code 2. Set Code 2 to [X77].

[Cod_2] [X77]

This setting enters the **smart register 1** code setup menu.

FIRST DIGIT
TIGER PROCESSING RATE
0 10 Hz
1 10 Hz
2 100 Hz
3 100 Hz

SECOND DIGIT
MEASUREMENT TASK
0 Voltage, Current
1 TC (3rd digit selects type of TC)
2 RTD 3-wire (3rd digit selects type of RTD)
3 RTD 2- or 4-wire (3rd digit selects type of RTD)
4 Frequency
5 Period
6 Counter
7 Smart Input Module

THIRD DIGIT
OUTPUT REGISTER MAP
0 Average Signal
1 Rapid Response Signal*
2 Peak Signal*
3 Valley Signal*
4 Capture Signal**
5 Rate of Change Signal
6 -
7 Smart input module register 1 code setup



Note the output registers in the 3rd digit are specific to the ISSC / ISSD input module. These registers vary for each different smart input module.

Note:

* Signal output at the A/D sampling rate.

** Hardware initiated from meter CAPTURE pin.

3 Press the **[P]** button to enter SMT1.

577E1 [000]

This menu provides settings unique to **smart register 1** of input module ISSC/ISSD.

FIRST DIGIT
LINE FREQUENCY SELECT
0 60 Hz rejection
1 -
2 50 Hz rejection
3 -

SECOND DIGIT
SENSOR INPUT mV/V
0 1 mV/V
1 2 mV/V
2 3 mV/V
3 20 mV/V
4 -
5 -
6 -
7 -

THIRD DIGIT
OUTPUT RATE
0 1 Hz average, 50/60 Hz rapid response
1 10 Hz average, 50/60 Hz rapid response
2 -
3 50/60 Hz average, 800/960 Hz rapid response
4 -
5 -
6 -
7 -

4 Using the **[↑]**/**[↓]** buttons, select:

1st Digit: **50 Hz** line frequency rejection for **50 Hz** power supply areas, or **60 Hz** line frequency rejection for **60 Hz** power supply areas.

2nd Digit: The sensor input range.

3rd Digit: The output rate.

5 Press the **[P]** button. The display returns to [Cod_2] [X77]. [Cod_2] [X77]

6 Using the **[↓]** button, reset the 3rd digit to zero [X70] to leave the smart register 1 menu. [Cod_2] [X70]

Note, leaving the 3rd digit as 7 means the display constantly cycles between [Cod_2] and [SMT1].

7 Press the **[↑]**/**[↓]** buttons to return to the operational display.

Channel Setup

Configure the required channel for each input signal type

- Status Input D1:** Set up CH1 in Code 2.
- Status Input D2:** Set up CH2 in Code 4.
- Load Cell Input:** Set up CH3 in Code 5 or CH4 in Code 6.

Status Input D1

Enter Code 2 and select the frequency range for CH1.

- 8** Press the **P** and **↑** buttons at the same time again to re-enter the main programming mode, then press the **P** button three times to enter Code 2.

Cod_2 000

- 9** Set Code 2 to [X4X] to configure status input D1 on CH1.

- 1st Digit:** Not relevant digital input D1.
- 2nd Digit:** Select **4** to enter the frequency range menu for digital input D1.
- 3rd Digit:** Select the required frequency range setting for digital input D1.

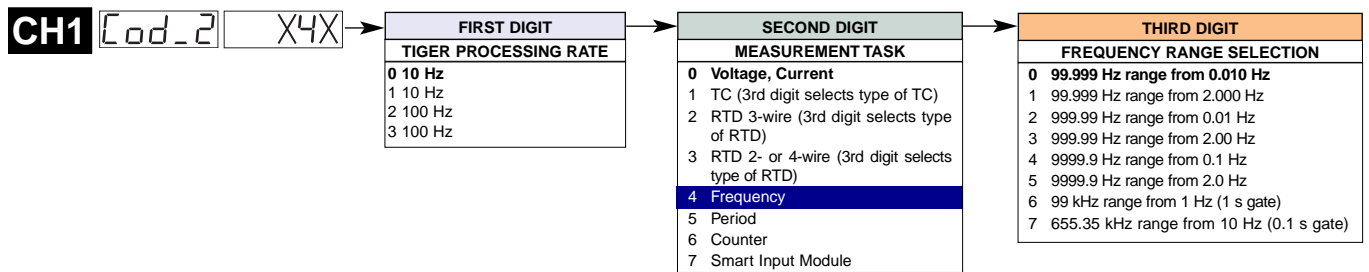

Status Input D2

Enter Code 4 and select the digital input for CH2.

- 10** Press the **P** button twice to enter Code 4.
- 11** Set Code 4 to [3X0] to configure status input D2 on CH2.

- 1st Digit:** Select **3** to enter the second digital input menu.
- 2nd Digit:** Select the frequency range for digital input D2.
- 3rd Digit:** Select **0** to apply **No user defined linearization on CH2**.

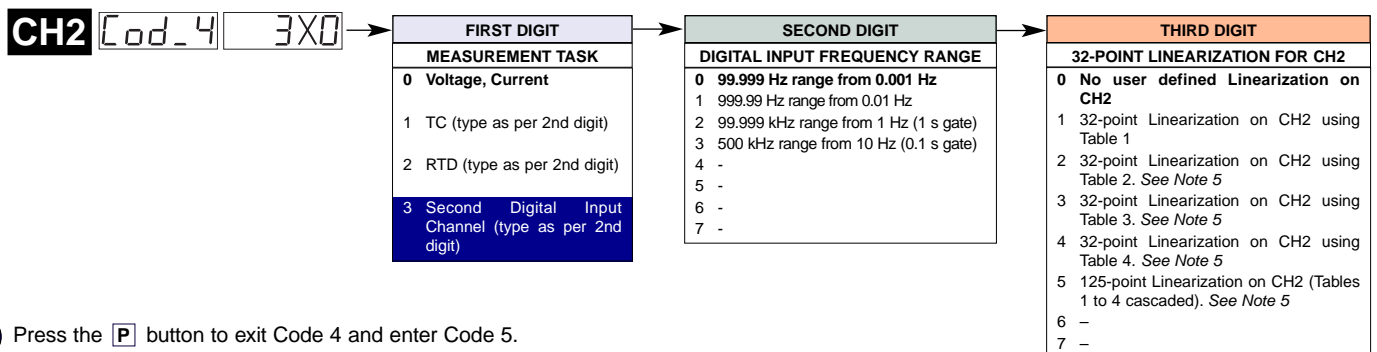

- 12** Press the **P** button to exit Code 4 and enter Code 5.

Load Cell Input

The load cell input can be selected for CH3 via Code 5 or CH4 via Code 6.

- 13** Set Code 5 to [07X] and select the required load cell output register for CH3 in the 3rd digit.

1st Digit: Set to **0** to select **Direct Display of Input**.

2nd Digit: Select **7** to enter the output register map for the load cell signal.

3rd Digit: Select the required output register setting for the load cell signal.

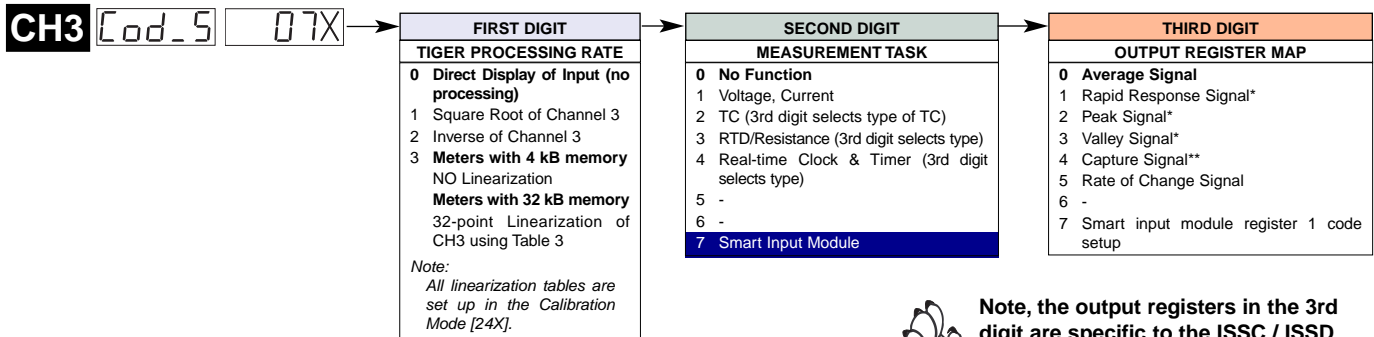

Note, the output registers in the 3rd digit are specific to the ISSC / ISSD input module. These registers vary for each different smart input module.

- 14** Press the **[P]** button to exit Code 5 and enter Code 6.

- 15** If a load cell output is required on CH4 set Code 6 to [07X] and select the required load cell output register for CH4 in the 3rd digit.

1st Digit: Set to **0** to select **Direct Display of Input**.

2nd Digit: Select **7** to enter the output register map for the load cell signal.

3rd Digit: Select the required output register setting for the load cell signal.

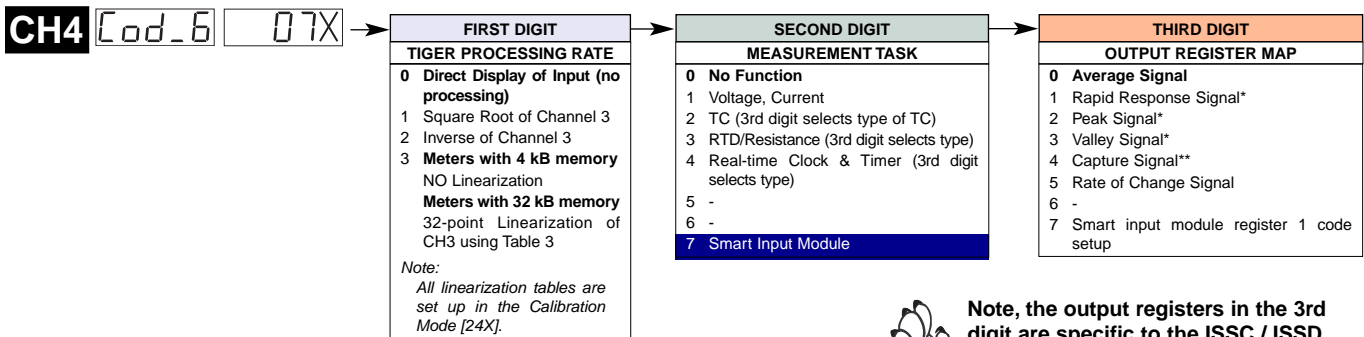

Note, the output registers in the 3rd digit are specific to the ISSC / ISSD input module. These registers vary for each different smart input module.

- 16** Press the **[P]** button to save the settings.

- 17** Press the **[P]** and **[↑]** buttons at the same time to return to the operational display.

Example Setup Procedure

In our example, a hopper fills boxes travelling along a conveyor belt. A rotary encoder monitors the conveyor speed and a light beam sensor indicates when the box to be filled is in position below the hopper. A load cell under the conveyor weighs the box.

The rotary encoder is connected to status input D1 and assigned to CH1. The light beam sensor is connected to status input D2 and assigned to CH2. The load cell is configured for 3 mV/V input with 50 Hz line frequency rejection. As the boxes are filled relatively quickly, the averaged output rate is set to 10 Hz on CH3.

The frequency output from the encoder is in the 0 to 1 kHz range (360 pulse/revolution). The light sensor has its beam broken at a much slower rate.

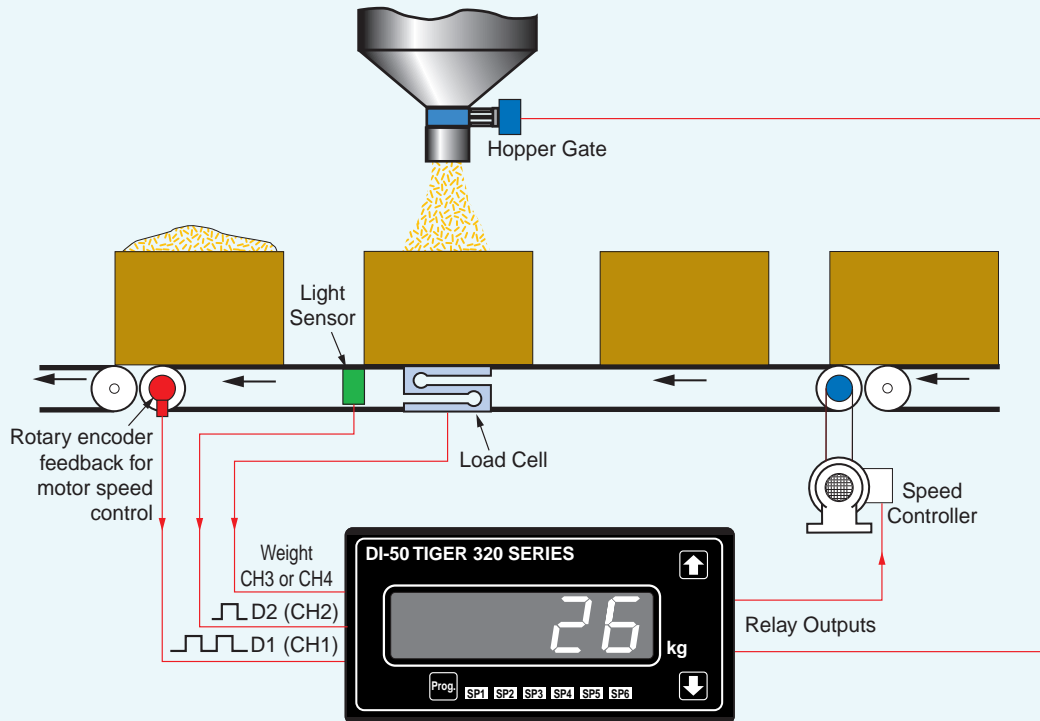

Figure 5 – Load Cell with Dual Status Inputs

Press the **[P]** and **[↑]** buttons at the same time to enter the main programming mode. Press the **[P]** button three times to enter Code 2.

1 Set up smart register 1 (SMT1) for 50 Hz line rejection, a 3 mV/V range, and 10 Hz averaged output rate:

In **[CODE 2]** select **[X77]** then press the **[P]** button.

Display toggles between **[SMT1 000]**

Set **[SMT1]** to **[231]**

2 Select the 1 kHz frequency range for the encoder on CH1:

In **[CODE 2]** reset to **[X42]** then press the **[P]** button twice.

3 Select the slowest frequency range for the light sensor on CH2:

In **[CODE 4]** select **[30X]** then press the **[P]** button.

4 Select the averaged load cell signal for CH3:

In **[CODE 5]** select **[X70]** then press the **[P]** button.

Press the **[P]** and **[↑]** buttons at the same time to return the main programming mode.

Customer Configuration Settings:

1st Digit 2nd Digit 3rd Digit

577E1

1st Digit 2nd Digit 3rd Digit

CH1 Cod_2

4

1st Digit 2nd Digit 3rd Digit

CH2 Cod_4

3

0

1st Digit 2nd Digit 3rd Digit

CH3 Cod_5

0

7

1st Digit 2nd Digit 3rd Digit

CH4 Cod_6

0

7

WARRANTY

Texmate warrants that its products are free from defects in material and workmanship under normal use and service for a period of one year from date of shipment. Texmate's obligations under this warranty are limited to replacement or repair, at its option, at its factory, of any of the products which shall, within the applicable period after shipment, be returned to Texmate's facility, transportation charges pre-paid, and which are, after examination, disclosed to the satisfaction of Texmate to be thus defective. The warranty shall not apply to any equipment which shall have been repaired or altered, except by Texmate, or which shall have been subjected to misuse, negligence, or accident. In no case shall Texmate's liability exceed the original purchase price. The aforementioned provisions do not extend the original warranty period of any product which has been either repaired or replaced by Texmate.

USER'S RESPONSIBILITY

We are pleased to offer suggestions on the use of our various products either by way of printed matter or through direct contact with our sales/application engineering staff. However, since we have no control over the use of our products once they are shipped, NO WARRANTY WHETHER OF MERCHANTABILITY, FITNESS FOR PURPOSE, OR OTHERWISE is made beyond the repair, replacement, or refund of purchase price at the sole discretion of Texmate. Users shall determine the suitability of the product for the intended application before using, and the users assume all risk and liability whatsoever in connection therewith, regardless of any of our suggestions or statements as to application or construction. In no event shall Texmate's liability, in law or otherwise, be in excess of the purchase price of the product.

Texmate cannot assume responsibility for any circuitry described. No circuit patent or software licenses are implied. Texmate reserves the right to change circuitry, operating software, specifications, and prices without notice at any time.

TEXMATE INC

995 Park Center Drive • Vista, CA 92081-8397

Tel: 1-760-598-9899 • USA 1-800-839-6283 • That's 1-800-TEXMATE

Fax: 1-760-598-9828 • Email: sales@texmate.com • Web: www.texmate.com

Texmate has facilities in Japan, New Zealand, Taiwan, and Thailand. We also have authorized distributors throughout the USA and in 28 other countries.

For product details visit www.texmate.com

Local Distributor Address