



LEOPARD FAMILY

Large display option  
0.8" red or green LED

**DL-40RPM**  
Leopard RPM Meter  
4 Digit 0.56" or 0.8" LEDs  
in a 1/8 DIN CASE



An economically smart meter relay for RPM measurement.

## General Features

- This meter has been designed specifically for RPM measurements. Just enter the pulses per revolution and the DL-40RPM meter will calculate and display the RPM reading.
- Three ranges with resolutions of 0.1 RPM, 1 RPM and 10 RPM (99.99 X 1000 RPM max.).
- Optional isolated 16 bit analog output. User or factory scalable to 4 to 20 mA, 0 to 20 mA or 0 to 10 V across any desired digital span from one count to the full scale range of 9999.
- 24 V DC excitation is available to power external sensors.
- Auto-sensing AC/DC power supply. For voltages between **85-265 V AC / 95-370 V DC (PS1)** or 15-48 V AC / 10-72 V DC (PS2).
- Standard red or optional green or super bright red 4-digit LED
- Red or green 0.8" LED large display option.
- Four annunciator LEDs provide front panel alarm status indication for up to four setpoints.
- Optional relays. Two 10 Amp Form C and two 5 Amp Form A relay, or optionally four 5 Amp Form A relays are available.

## Software Features

- Three-button programming from the front panel (UP, DOWN and PROGRAM buttons).
- Three front panel selectable ranges.
- Front panel selectable four-level brightness control of digital display, and setpoint LEDs.
- Four programmable setpoints.
- Relay activation can be selected to occur above (HI) or below (LO) each setpoint.
- Hysteresis setting for all four setpoints. Delay on make and delay on break for SP1 and SP2.
- Peak and Valley. View and Reset.

## Input Module Compatibility

There is 1 Plug-in Modular Input Signal Conditioner, IF05, for this specialized RPM only member of the Leopard Family.



LEOPARD

## Specifications

**Input Specs:** .....Depends on Input Signal Conditioner  
**A/D Converter:** .....14 Bit Single Slope  
**Accuracy:** .....±1 count  
**Temp. Coeff.:** .....100 ppm/°C (Typical)  
**Warm up time:** .....2 minutes  
**Conversion Rate:** .....5 conversions per second (Typical)  
**Display:** .....**4 digit 0.56" Red LED display (std)**,  
 0.56" or 0.8" Red, Green or Super Bright Red (optn). Range to 9999 counts.  
**Polarity:** .....Assumed positive.  
**Decimal Selection:** .....Automatic by selection of resolution  
**Positive Overrange:** ...Top segments of digital display flash  
**Relay Output:** .....Two 5 Amp Form A relays and two 10  
 Amp Form C, or 5 Amp form A relays.  
**Analog Output:** .....Isolated 16 bit user scalable mA or V  
 AIC (mA out) .....4-20 mA @ 0 to 500Ω max loop resistance  
 AIV (volts out) .....0-10 V DC @ 500 Ω or higher resistance  
**Power Supply:** .....AC/DC Auto sensing wide range supply  
**PS1 (std)** .....**85-265 VAC / 95-370 VDC @ 2.5W max 3.5W**  
**PS2** .....15-48 VAC / 10-72 VDC @ 2.5W max 3.5W  
**Operating Temp.:** .....0 to 60 °C  
**Storage Temp:** .....-20 °C to 70 °C.  
**Relative Humidity:** .....95% (non condensing)  
**Case Dimensions:** ....11/8 DIN, Bezel: 96x48 mm  
 (3.78"x1.89")  
 Depth behind bezel: 117 mm (4.61")  
 Plus 11.8 mm (0.47") for Right-angled  
 connectors, or plus 20 mm (0.79") for  
 Straight-thru connector.  
**Weight:** .....6.5 oz., 8.5 oz when packed

## Index

Case Dimensions .....	10	General Features .....	1	Ordering Information .....	12	Specifications .....	1
Component Layout .....	8-9	Glossary of Programming Symbols .....	2	Pin Descriptions .....	8	Two Point Analog Output	
Connector Pinouts .....	7-8	Input Module Compatibility .....	1	Pulses Per Revolution, Range		Range Setting & Calibration .....	4
Controls and Indicators .....	2	I-Series Input Signal Conditioning		& Brightness Selection .....	4		
Digital Span Selection for		Modules .....	10	Setpoint Setting & Relay Configuration Mode .....	6		
Analog Range Output .....	5	Lens Cover OP-N4X/96X48 .....	11	Software Features .....	1		
Functional Diagram .....	7	Metal Surround Case OP-MTL96X48 .....	11	Software Logic Tree .....	3		

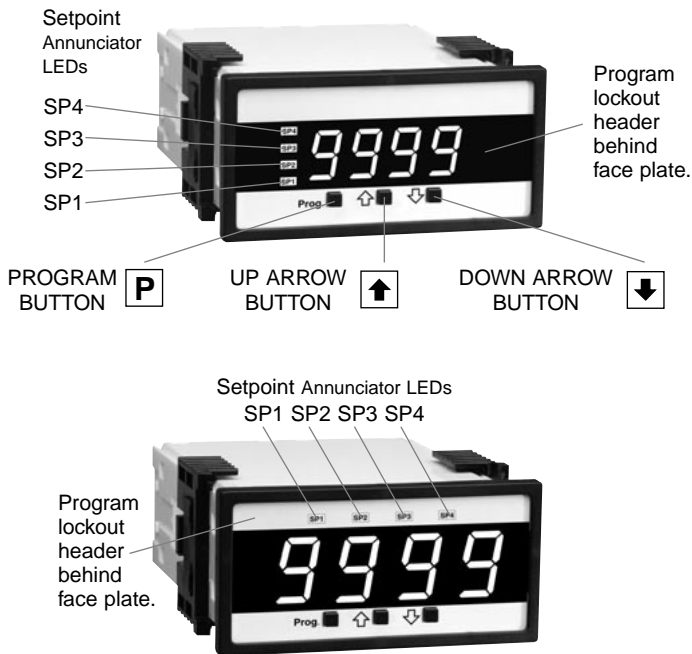

## Front Panel Buttons

### Program Button

The **[P]** button is used to move from one program step to the next. When pressed at the same time as the **[↑]** button, it initiates the **calibration mode**. When pressed at the same time as the **[↓]** button, it initiates the **setpoint setting mode**.

### Up Button

When in the operational display, pressing the **[↑]** button alone allows you to view, but not change, the setting of **setpoint 1**.

When in the **calibration mode** or the **setpoint setting mode** the **[↑]** button is used to increase the value of the displayed parameter.

### Down Button

When in the operational display, pressing the **[↓]** button alone allows you to view, but not change, the setting of **setpoint 2**.

When in the **calibration mode** or the **setpoint setting mode** the **[↓]** button is used to decrease the value of the displayed parameter.

## Glossary of Programming Symbols

To explain software programming procedures, logic diagrams are used to visually assist in following the programming steps. The following symbols are used throughout the logic diagrams to represent the buttons and indicators on the meter:

Symbol	Explanation
	This symbol represents the OPERATIONAL DISPLAY.
	This is the PROGRAM button.
	This is the UP ARROW button.
	This is the DOWN ARROW button.
	When a button is shown, press and release it to go onto the next step in the direction indicated by the arrow. When two or more buttons are shown, each with an arrow, this indicates that there is a number of programming choices.
	When two buttons are shown side by side and enclosed by a dotted line, they must be pressed at the same time then released to go onto the next programming step.
	If the display is shown with XXXX, it means the value displayed will be the previously set value. When a number is shown, it indicates the initial factory default setting or a specific "example number".

When two displays are shown together with bursts, this indicates that the display is toggling (flashing) between the name of the function and the value.

Text or numbers shown between square brackets in a procedure indicate the programming code name of the function or the value displayed on the meter display.

When the **[↑]** and **[↓]** buttons are shown together, the display value can be increased by pressing and releasing the **[↑]** button or decreased by pressing and releasing the **[↓]** button.

When the **[↑]** and **[↓]** buttons are shown with two displays, either display can be selected by pressing and releasing the **[↑]** or **[↓]** buttons.

When there are more than two display selections they are shown in brackets below the first display and are also selectable by pressing and releasing the **[↑]** or **[↓]** buttons.

A dotted box indicates these functions are omitted or bypassed when the related hardware is not present.

The DL-40RPM is an intelligent meter with a hierarchical software structure designed for easy programming and operation, as shown below in the software logic tree.

After the meter has been powered up, the four digits light up for three seconds and then settle to the operational display indicating the input signal.

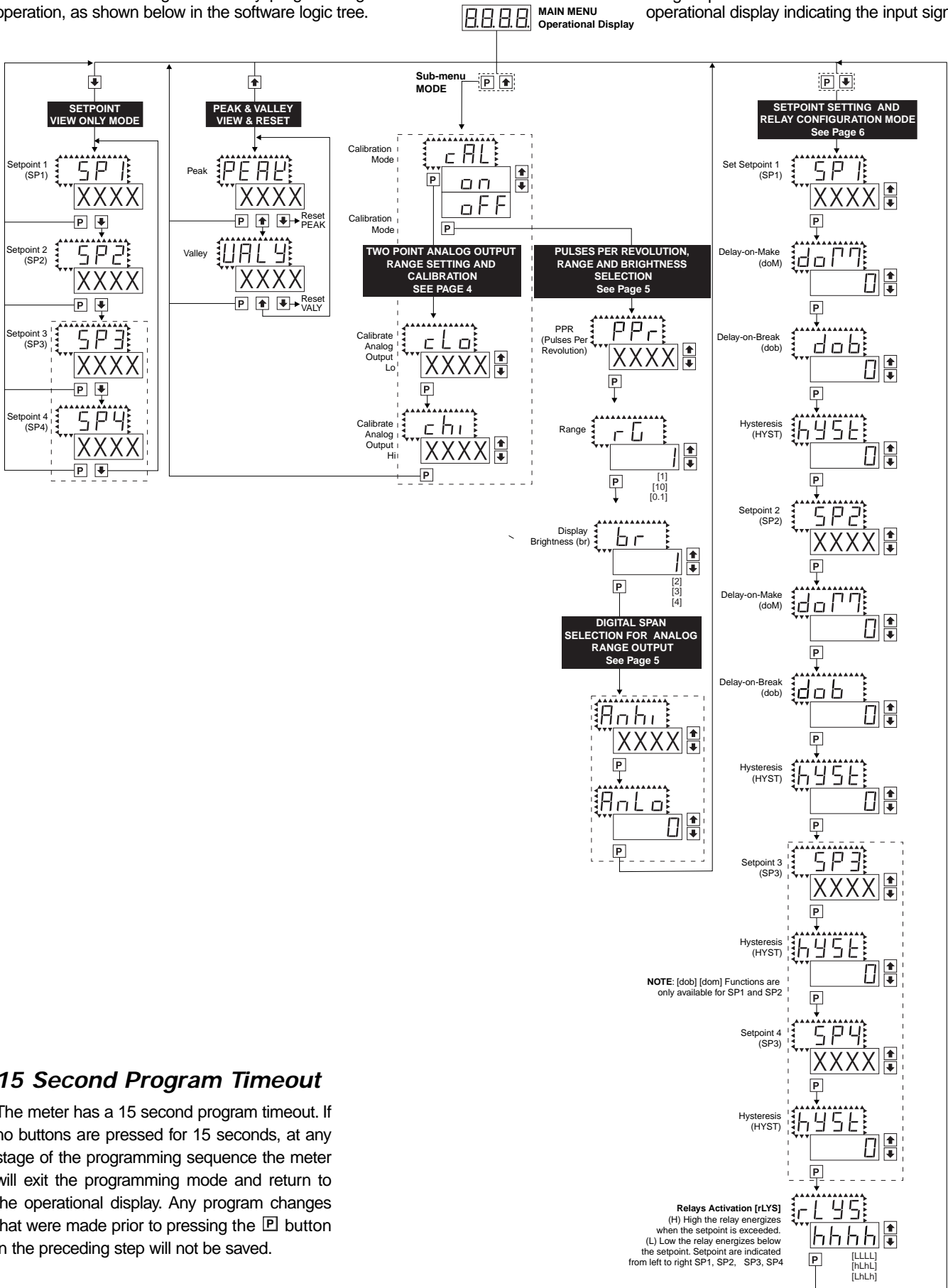

## 15 Second Program Timeout

The meter has a 15 second program timeout. If no buttons are pressed for 15 seconds, at any stage of the programming sequence the meter will exit the programming mode and return to the operational display. Any program changes that were made prior to pressing the [P] button in the preceding step will not be saved.

## Two Point Analog Output Range Setting and Calibration

### STEP A Enter the Calibration Mode

- 1) Press the **[P]** and **[↑]** buttons at the same time. Display toggles between [cAL] and [oFF] if the Analog Output option is installed.

**Note:** If at this point the display skips directly to toggle between [PPr] and the previous Pulses per revolution setting (STEP E) then the software is detecting that the optional analog output hardware is NOT installed.

### STEP B Enter the [oUT] Analog Output Calibration Mode

- 1) Press the **[↑]** or **[↓]** button. Display changes from [oFF] to [on].
- 2) Press the **[P]** button. Display toggles between [cLo] and an internal scale factor.

### STEP C Calibrate the [cLo] Low Analog Output

- 1) Select the voltage or current output header position on the output module. (See Component Layout on page 9).
- 2) Connect a multimeter to pins 16 and 17 on the output module. (See Rear Panel Pinouts on page 8). Using the **[↑]** and **[↓]** buttons, adjust the analog output to the desired low value as shown on the multimeter display. cLo may be adjusted to any value from -0.3 mA to 17 mA (mA output selected) or from -0.6 V to 8 V (volt output selected)
- 3) Press the **[P]** button. Display toggles between [chi] and an internal scale factor.

### STEP D Calibrate the [chi] High Analog Output

- 1) Using the **[↑]** and **[↓]** buttons, adjust the analog output to the desired high value as shown on the multimeter display. chi may be adjusted to any value from 17 mA to 21 mA (mA output selected) or from 8 V to 10.3 V (volt output selected)
- 2) Press the **[P]** button. The display exits the calibration mode and returns to the operational display.

**Note:** Having established the Low and High range of the analog output, the digital span can now be selected which will set the two display points between which the analog output will occur. (See STEP I and STEP J on Page 5).

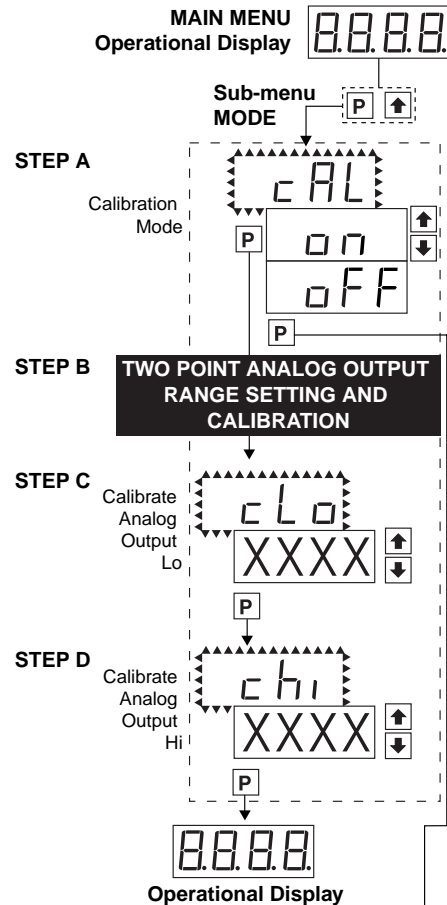

## Pulses Per Revolution, Range and Brightness Selection

### STEP E Enter the Range Selection Mode Through the Sub Menu [cAL] [oFF]

- 1) Press the **[P]** and **[↑]** buttons at the same time. Display toggles between [cAL] and [oFF].
- 2) Press the **[P]** button. Display toggles between [PPr] and the previous pulses per revolution setting.

### STEP F Enter the Pulses per revolution (PPR)

- 1) Using the **[↑]** and **[↓]** buttons, enter the number of pulses per revolution. Any number between 1 and 9999 may be entered.
- 2) Press the **[P]** button. Display toggles between [rG] and the previous range setting.

### STEP G Select the Range

- 1) Using the **[↑]** and **[↓]** buttons, select the required range. There are three ranges with resolutions of 0.1 (max. 999.9 RPM), 1 (max. 9999 RPM) and 10 RPM (max. 99.99 X 1000 RPM).
- 2) Press the **[P]** button. Display toggles between [br] and the previous brightness setting.

### STEP H Set the Display Brightness

- 1) Using the **[↑]** and **[↓]** buttons, adjust the display to the desired brightness setting (4 is the brightest setting).
- 2) Press the **[P]** button. Display brightness changes to new setting and display toggles between [Anhi] and the previous [Anhi] setting, if the Analog Output Option is installed.

**Note:** If the Analog Output option is not installed then the displays returns to the operational display.

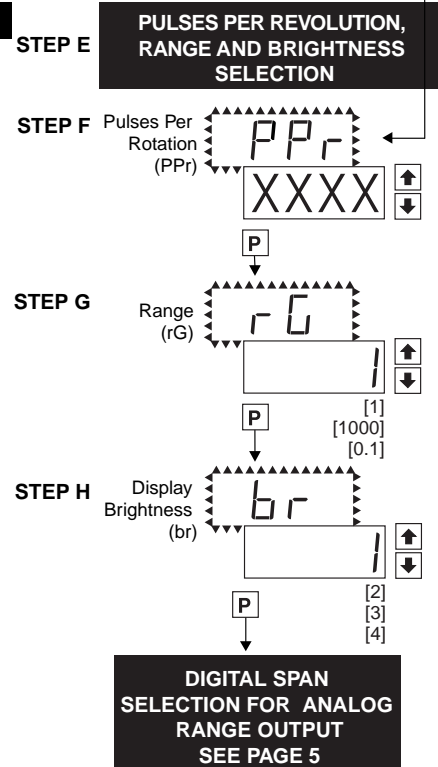

## Digital Span Selection for Analog Range Output

### STEP I Set the Display Corresponding to the Analog High Output

- 1) Using the  $\uparrow$  and  $\downarrow$  buttons, adjust the display to the desired value at which the selected analog high output will occur.
- 2) Press the  $\text{P}$  button. Display toggles between [AnLo] and previous [AnLo] setting.

### STEP J Set the Display Corresponding to the Analog Low Output

- 1) Using the  $\uparrow$  and  $\downarrow$  buttons, adjust the display to the value at which the selected analog low output range will occur.
- 2) Press the  $\text{P}$  button. The display exits the calibration mode and returns to the operational display.

**Note:** Any two points from 0 to 9999 can be selected for which the specified analog output occurs. The display values for analog high and analog low can be reversed for reversed 20-4 mA output. The difference between the two display points can be as small as two counts however small spans cause the 16 bit D to A to increment in staircase steps.

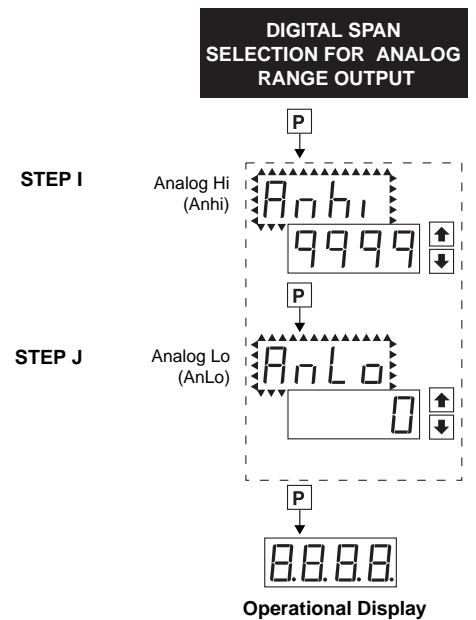

# Setpoint Setting and Relay Configuration Mode

The following programming steps are required to enter the setpoint values and configure the relay functions in a meter with four relays using four setpoints. Generally if less than four relays are installed the software auto detects missing relays and deletes reference to them from the menu. In some cases setpoints without relays are operational for display only purposes.

## STEP A Enter the Setpoint Mode

- 1) Press the **P** and **↓** buttons at the same time.  
Display toggles between [SP1] and the previous [SP1] setting.

## STEP B Set Setpoint 1 (SP1)

- 1) Using the **↑** and **↓** buttons, adjust the display to the desired SP1 value.
- 2) Press the **P** button. Display toggles between [doM] and the previous [doM] setting.

## STEP C Set the SP1 Delay-on-Make (doM) Delay Time Setting

- 1) Using the **↑** and **↓** buttons, adjust the display to the desired [doM] value (0 to 9999 seconds). The reading must continuously remain in an alarm condition until this delay time has elapsed before the relay will make contact (energize).
- 2) Press the **P** button. Display toggles between [dob] and the previous [dob] setting.

## STEP D Set the SP1 Delay-on-Break (dob) Delay Time Setting

- 1) Using the **↑** and **↓** buttons, adjust the display to the desired [dob] value (0 to 9999 seconds). The reading must continuously remain in an alarm condition until this delay time has elapsed before the relay will break contact (de-energize).
- 2) Press the **P** button. Display toggles between [hYSt] and the previous [hYSt] setting.

## STEP E Set the Hysteresis Setting for Setpoint 1

- 1) Using the **↑** and **↓** buttons, adjust the display to the desired hysteresis [hYSt] value.
  - 2) Press the **P** button. Display toggles between [SP2] and the previous [SP2] setting.
- NOTE:** Half of the Hysteresis value selected is applied above and below the setpoint.

**NOTE:** Steps F, G, H and J have functionally the same procedure as steps B, C, D, and E shown above.

## STEP F Set Setpoint 2 (SP2)

## STEP G Set the SP2 Delay-on-Make (doM) Delay Time Setting

## STEP H Set the SP2 Delay-on-Break (dob) Delay Time Setting

## STEP I Set the Hysteresis Setting for Setpoint 2

- 1) Using the **↑** and **↓** buttons, adjust the display to the desired hysteresis [hYSt] value.
- 2) Press the **P** button. Display toggles between [SP3] and the previous [SP4] setting.

## STEP J Set Setpoint 3 (SP3) (No [doM] or [dob])

- 1) Using the **↑** and **↓** buttons, adjust the display to the desired SP3 value.
- 2) Press the **P** button. Display toggles between [hYSt] and the previous [hYSt] setting.

## STEP K Set the Hysteresis Setting for Setpoint 3

- 1) Using the **↑** and **↓** buttons, adjust the display to the desired hysteresis [hYSt] value.
- 2) Press the **P** button. Display toggles between [SP4] and the previous [SP4] setting.

## STEP L Set Setpoint 4 (SP4) (No [doM] or [dob])

- 1) Using the **↑** and **↓** buttons, adjust the display to the desired SP4 value.
- 2) Press the **P** button. Display toggles between [hYSt] and 0.

## STEP M Set the Hysteresis Setting for Setpoint 4

- 1) Using the **↑** and **↓** buttons, adjust the display to the desired hysteresis [hYSt] value.
- 2) Press the **P** button. Display toggles between [rLYS] and the previous relay setting.

## STEP N Set Relay Activation mode [rLYS]

(h) High the relay energizes when the setpoint is exceeded. (L) Low the relay energizes below the setpoint. The setpoint is indicated from left to right SP1, SP2, SP3, SP4.

- 1) Using the **↑** and **↓** buttons, adjust the reading on the display to the desired relay settings: [LLLL], [LhLh], [LLhh], [hhhh].

If only 2 relays installed [Lh] [hL] [hh] [LL].

- 2) Press the **P** button.

The meter exits the setpoint mode and returns to the operational display.

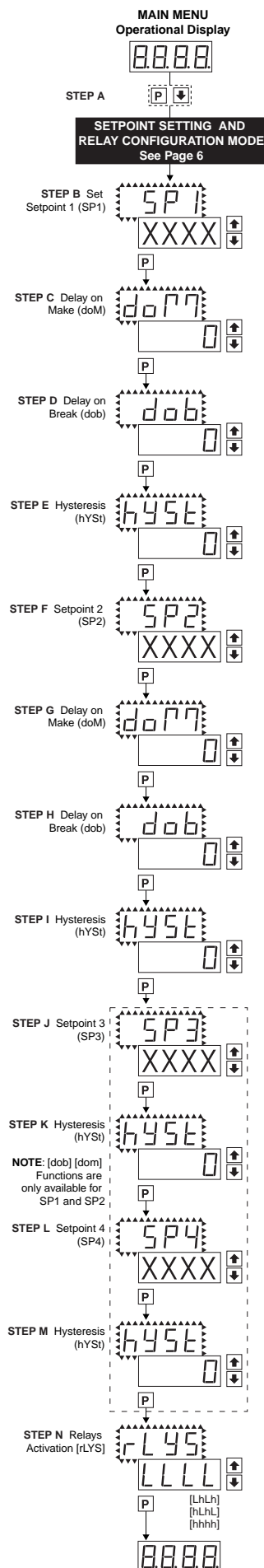

The Setpoint Relay programming mode is now complete.

# Functional Diagram

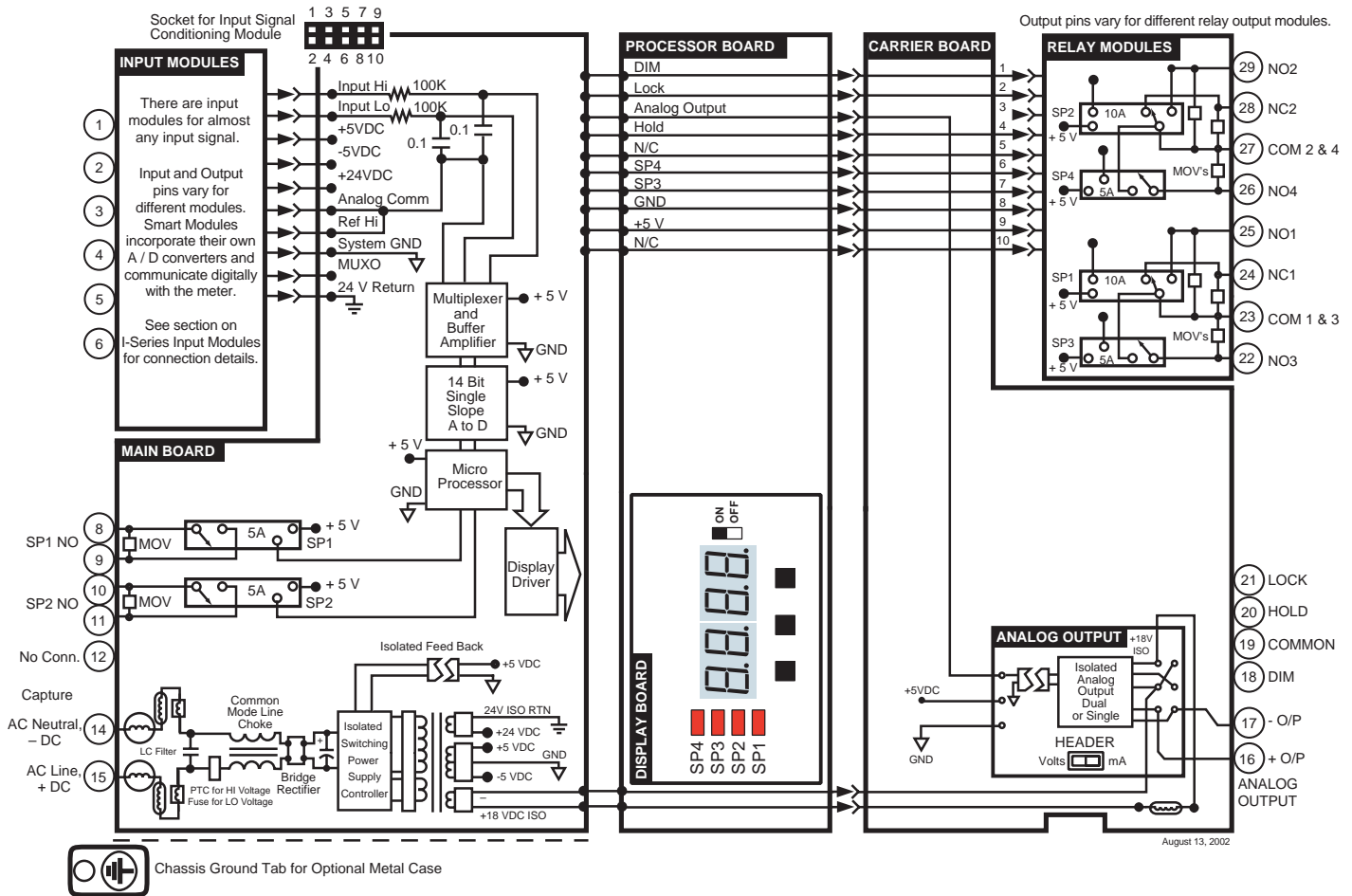

## Connector Pinouts

### Pinout Diagram

The Rear View of the Meter diagram shows the meter with the relay configuration: dual 10 Amp Form C and dual 5 Amp Form A relays. An analog output module is also shown as installed.

The DL-40RPM uses plug-in type screw terminal connectors for all input and output connections. The power supply connections (pins 14 and 15) have a unique plug and socket outline to prevent cross connection. The main board and input signal conditioner use right-angled connectors as standard. The output module uses straight-thru connectors as standard.



**WARNING:** AC and DC input signals and power supply voltages can be hazardous. Do Not connect live wires to screw terminal plugs, and do not insert, remove or handle screw terminal plugs with live wires connected.

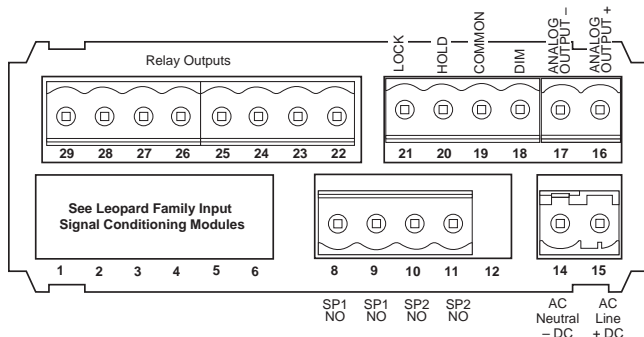

Auto-sensing AC/DC power supply. For voltages between 85-265 V AC / 95-370 V DC (PS1) or 18-48 V AC / 10-72 V DC (PS2).

Standard plug-in screw terminal connectors provided by Texmate:

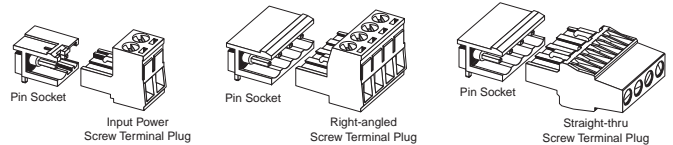

### Input Signal – Pins 1 to 6

Pins 1 to 6 are reserved for the input signal conditioner. See the data sheet for the selected input signal conditioner.

### Pins 8 to 12 – Relay Output Pins

Note: If relays for setpoints 1 & 2 are installed on the main board, and a relay output module is used that also has relays in the setpoints 1 & 2 positions, the duplicate relays will operate in unison.

- Pin 8 SP1 NO.
- Pin 9 SP1 NO. Normally Open 5 Amp Form A.
- Pin 10 SP2 NO.
- Pin 11 SP2 NO. Normally Open 5 Amp Form A.
- Pin 12 NO CONNECTION.

### Pins 14 and 15 – AC/DC Power Input

Auto-sensing AC/DC power supply. For voltages between 85-265 V AC/95-370 V DC (PS1) or 18-48 V AC/10-72 V DC (PS2).

- Pin 14 AC/DC Neutral. Neutral power supply line.
- Pin 15 AC/DC line. Live power supply line.

### Optional Carrier Board Output Pins

#### Pins 16 and 17 – Analog Output

Pins 16 and 17 are the analog output pins on the optional output module. Their pin definitions are:

- Pin 16 Positive (+) analog output.
- Pin 17 Negative (-) analog output.

## Connector Pinouts continued

### Pins 18 to 21 – Rear Panel Function Pins

Pins 18 to 21 provide functions that can be implemented with an external switch. Their pin definitions are:

**Pin 18 DIM.** By connecting the display dim (DIM) pin to the COMMON pin, the display brightness setting is halved.

**Pin 19 COMMON.** To activate the LOCK or DIM functions from the rear of the meter, the respective pins have to be connected to the COMMON pin. This pin is connected to the internal power supply ground.

**Pin 20 HOLD.** By connecting the HOLD pin to the COMMON pin, the displayed reading is frozen, however, A/D conversions continue. When the HOLD pin is disconnected from the COMMON pin, the correct reading is displayed.

**Pin 21 LOCK.** By connecting the LOCK pin to the COMMON pin, the meter's programmed parameters can be viewed but not changed.

### Pins 22 to 29 – Output Module Pins

Relay Modules with 4 Independent 400V (210mA DC only) or (140mA AC/DC) SSRs

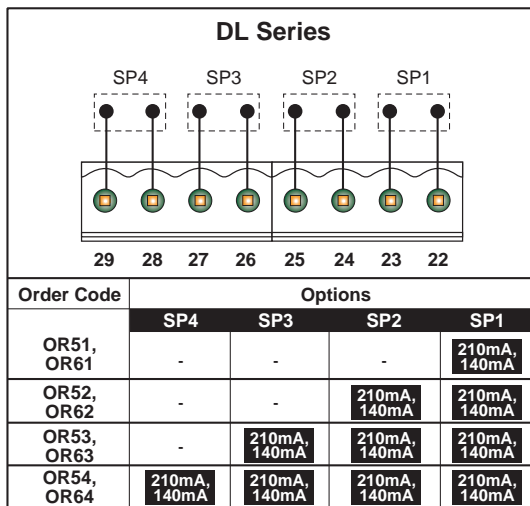

Relay Modules with 2 Non-Isolated 5A Form A Relays, and 2 Non-Isolated 10A Form C Relays

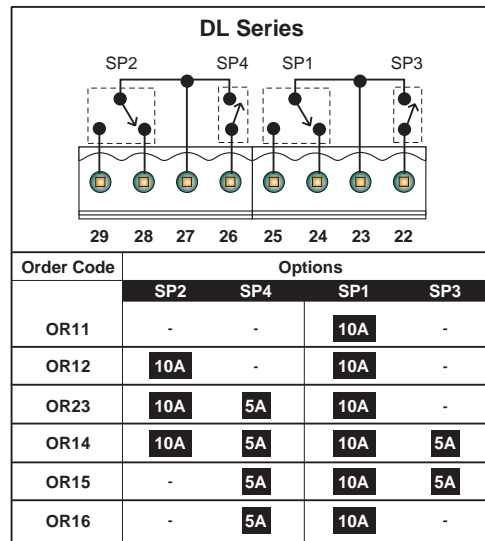

Relay Modules with 4 Isolated 5A Form A Relays

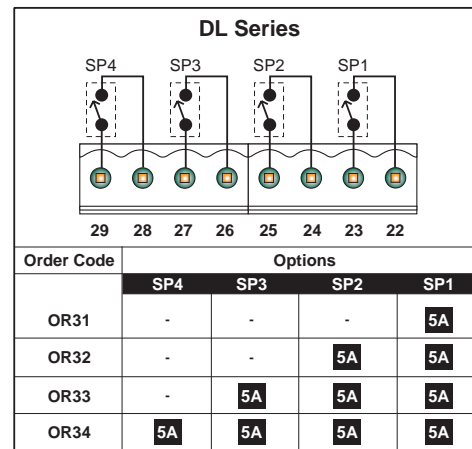

## Component Layout

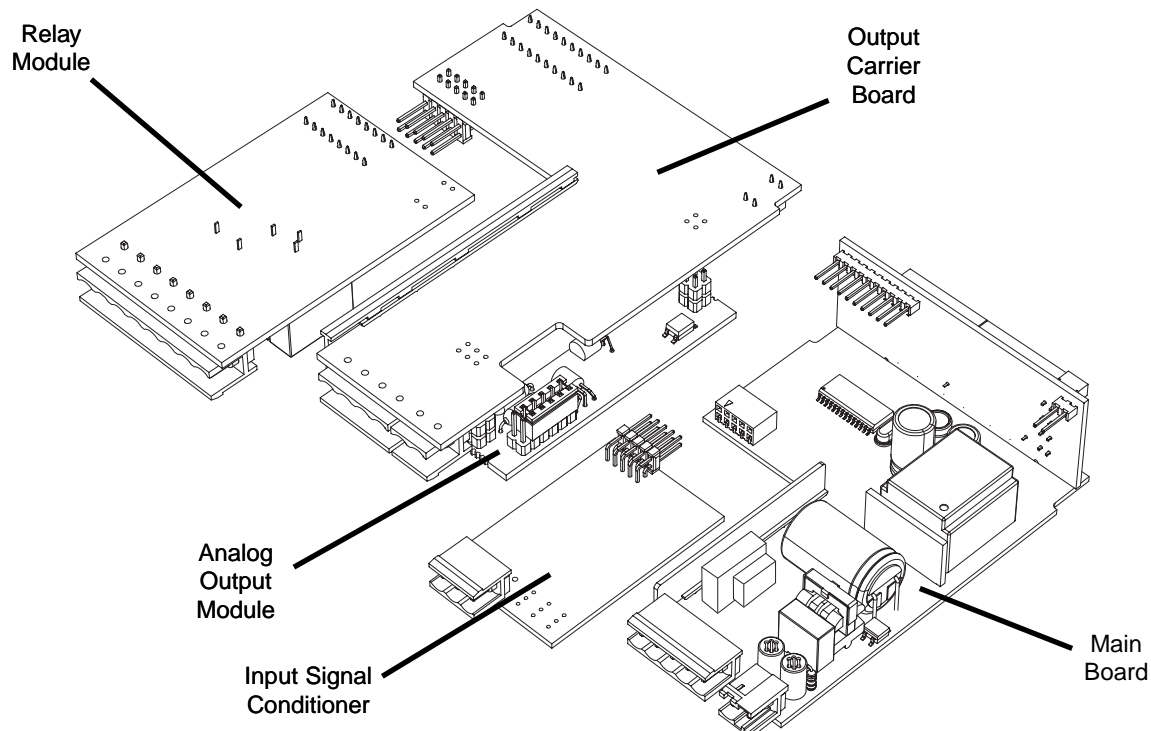

**Display Board – Front View**

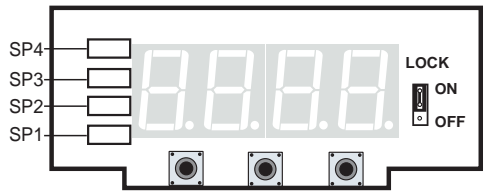

**0.56" LED Display Board - Front View**

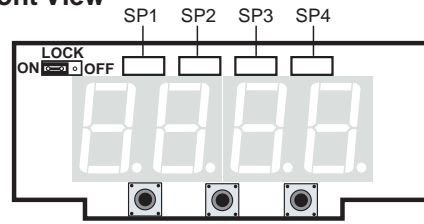

**0.8" LED Display Board - Front View**

**High Volt Main Board**

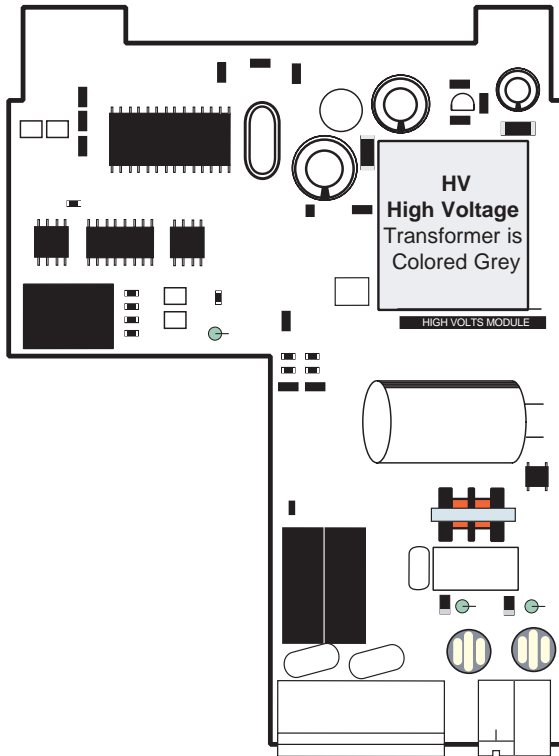

**Low Volt Main Board**

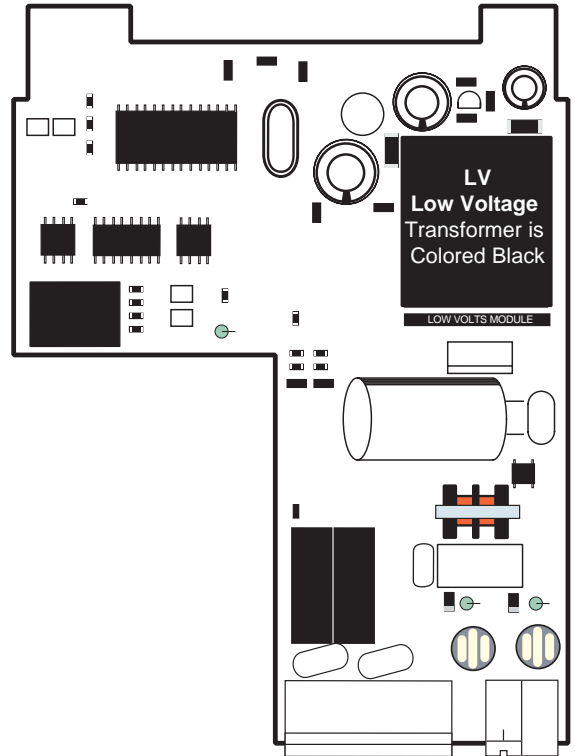



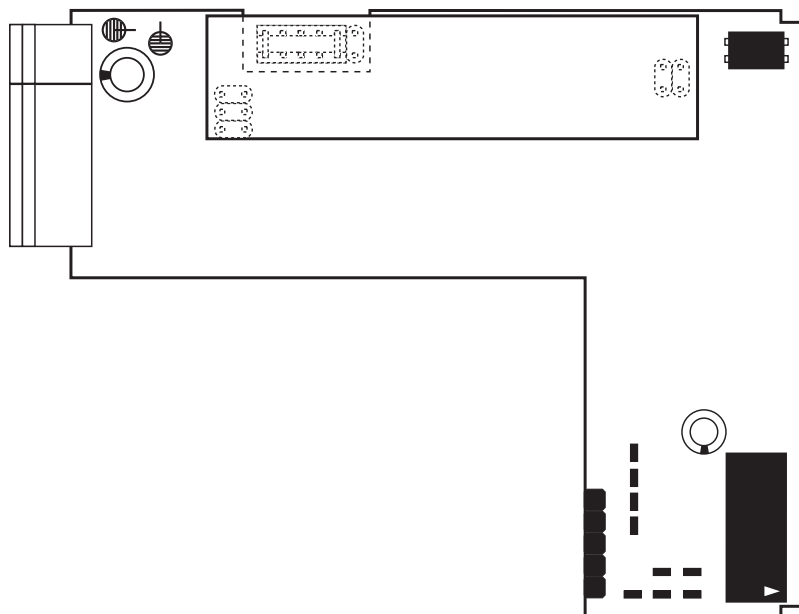





**Output Module Carrier Board**



# I-Series Input Signal Conditioning Modules

## Symbols Indicate Module Compatibility Within Meter Families

 TIGER Family	 LEOPARD Family	 LYNX Family
 TIGER Family	 LEOPARD Family	 LYNX Family
 TIGER Family	 LEOPARD Family	 LYNX Family
<b>ALL MODELS</b>	<b>SOME MODELS</b>	<b>MODEL SPECIFIC</b>

Unless otherwise specified Texmate will ship all modules pre-calibrated with factory preselected ranges and/or scalings as shown in **BOLD** type. Other pre-calibrated standard ranges or custom ranges may be ordered. Factory installed custom scaling and other custom options are also available (see Ordering Information, Special Options on last page).

## IF05: Universal Frequency / RPM

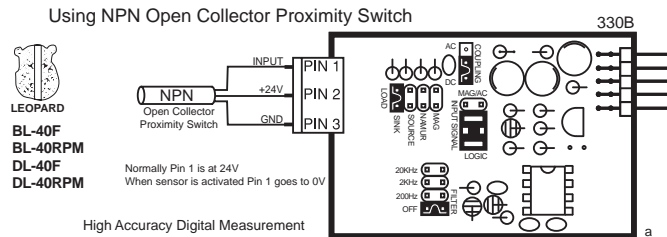

**WARNING:** AC and DC input signals and power supply voltages can be hazardous. Do Not insert, remove or handle modules with live wires connected to any terminal plugs.

## Case Dimensions

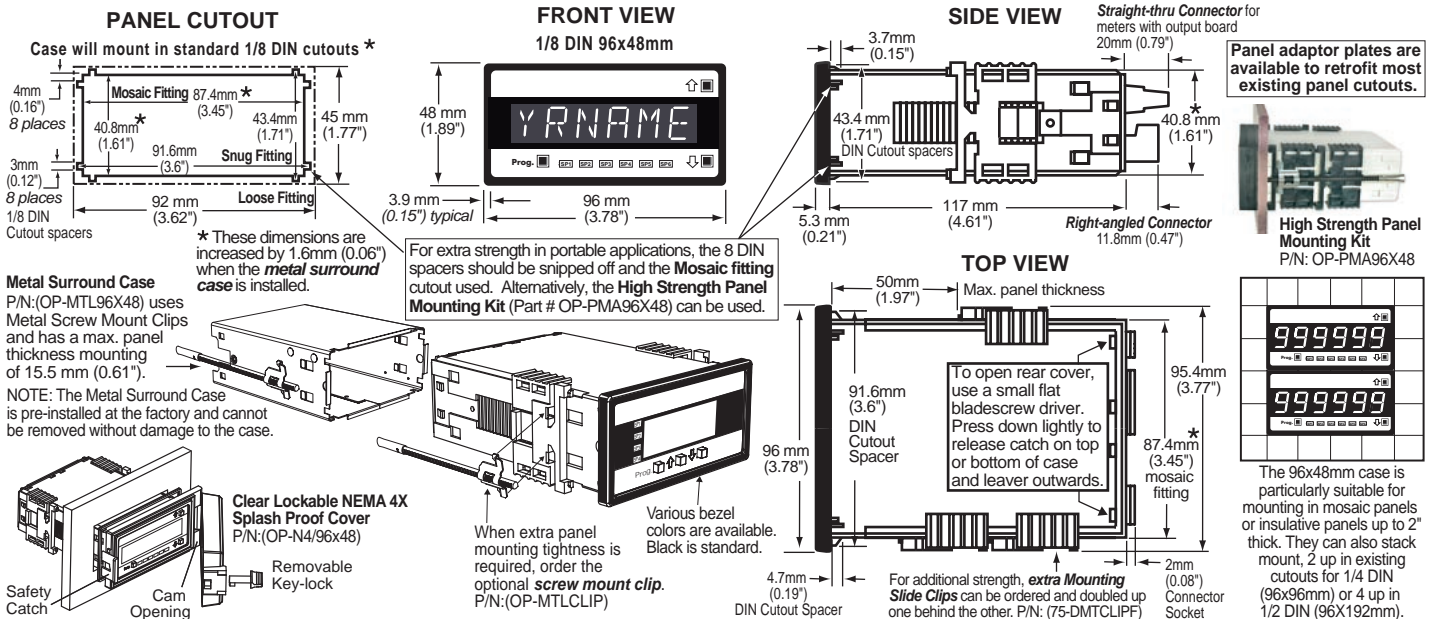

## Lens Cover OP-N4X/96X48

The lens cover is designed to be dust and water proof to NEMA-4 standards. The lens cover consists of a base and cover with a cam hinge and key-lock locking device.

An O-ring, or neoprene gasket forms a seal between the base and the panel. The cam hinge prevents the cover from closing when opened until pushed closed. The cover has a tapered recess that, when closed, forms a capillary seal with a tapered ridge on the base. Turning the key-lock tightens the cover to the base, ensuring seal integrity. A safety catch keeps the cover closed even when the key is turned to the open position and removed. The keyhole can also be used to attach a safety seal clip, preventing unauthorized opening.

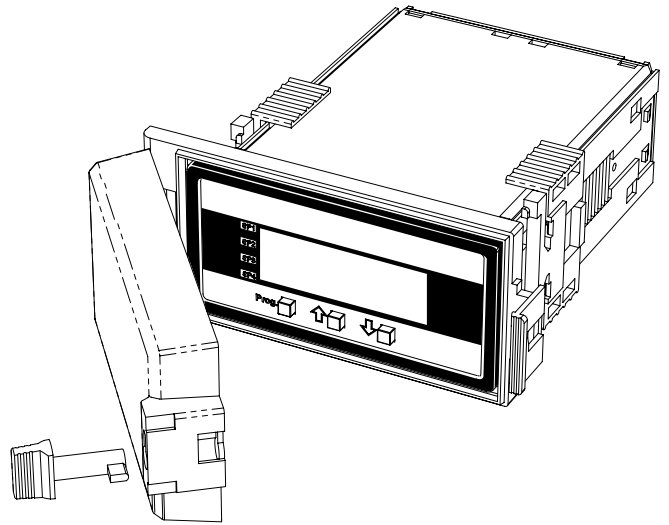

## Metal Surround Case OP-MTL96X48

The meter's plastic case is made from fire retardant polycarbonate. A metal surround case can be ordered to enhance the meter's fire retardant capabilities and also provide shielding against electromagnetic interference (EMI). The metal case slides over the polycarbonate case and is held firmly in place by spring-type non-return clips. Once the metal case has been fitted to the polycarbonate case it cannot be removed.

With the metal case in place, the meter's plastic ratchet-type mounting clips can no longer be used. A pair of screw-type mounting clips are inserted into holes on the side of the metal case and used to mount the meter in the panel. A ground tab on the metal case provides a ground connection between the meter's main board and the metal case.

\* Metal Surround Case must be factory installed.

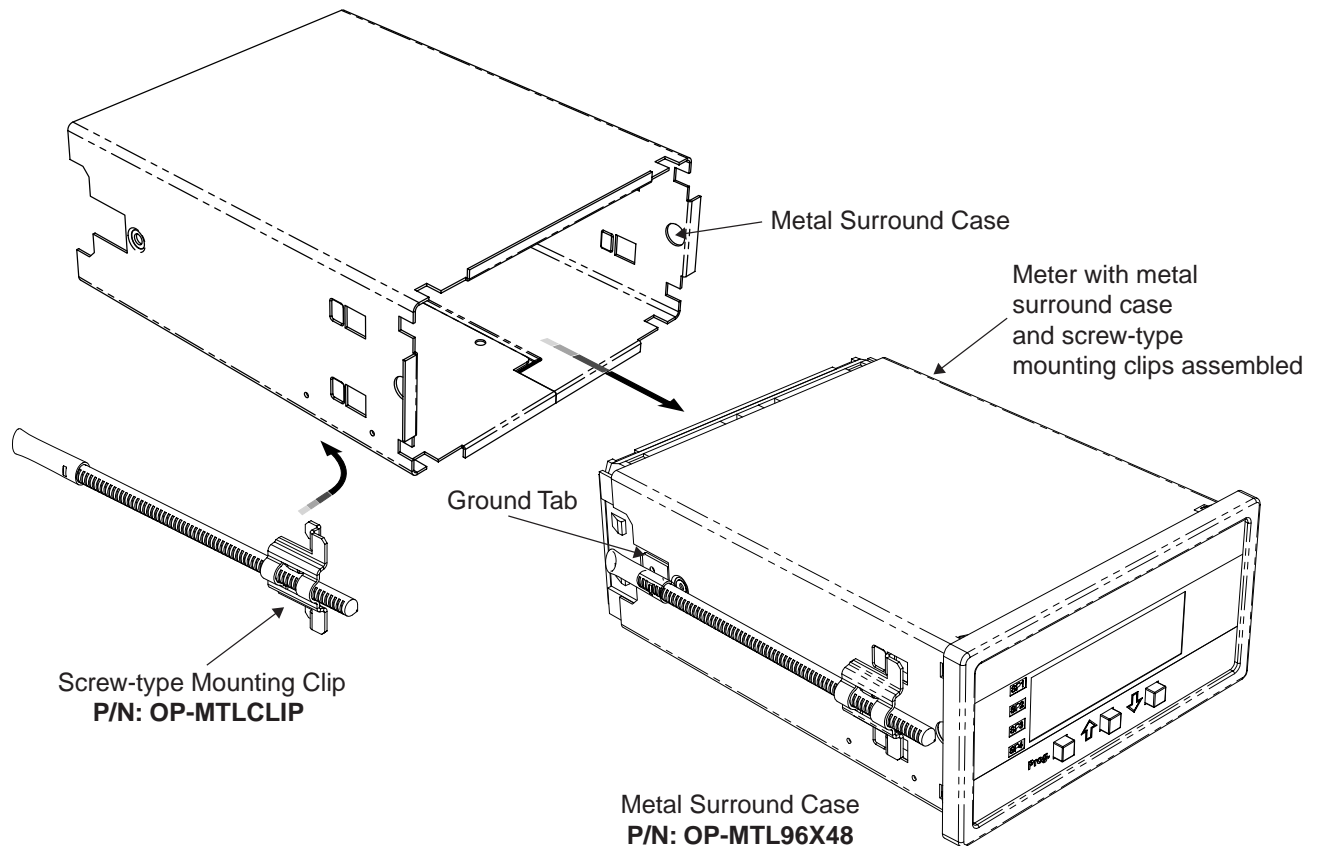

## Ordering Information

**BASIC MODEL #**      **DISPLAY**      **POWER SUPPLY**      **INPUT MODULES**      **ANALOG OUTPUT\***      **RELAY OUTPUT\***      **OPTIONS / ACCESSORIES**

**DL-40RPM** — [ ] — [ ] — [ ] — [ ] — [ ] — **OA** [ ]

Add to the basic model number the order code suffix for each standard option required. The last suffix is to indicate how many different special options and or accessories that you may require to be included with this product. \*Except when when R1 or R2 relay output is selected, a meter ordered with an analog output or a relay output module requires an Output Module Carrier Board which should be automatically included with the order, with an additional charge. (See special Options and Accessories section)

**Ordering Example: DL-40RPM-DR-PS1-IA01-AIC-R1-OA2, the 2 OA's are, CR-CHANGE and a OP-N4X/96X48**

### ► BASIC MODEL NUMBER

DL-40RPM . . . 96x48mm, Leopard, 4 Digit, RPM Meter

### Standard Options for this Model Number

#### Order Code Suffix

#### Description

#### ► DISPLAY

DR . . . Red LED, 0.56 inch high  
 DB . . . Super-bright Red LED, 0.56 inch high  
 DG . . . Green LED, 0.56 inch high  
 LG . . . Large Green LED, 0.8 inch high  
 LR . . . Large Red LED, 0.8 inch high

#### ► POWER SUPPLY

PS1 . . .85 - 265VAC / 95 - 370VDC  
 PS2 . . .15 - 48VAC / 10 - 72VDC

#### ► INPUT MODULES (Partial List. See www.texmate.com)

Unless otherwise specified Texmate will ship all modules precalibrated with factory preselected ranges and/or scalings as shown in BOLD type.

IF05 . . . Universal Frequency/RPM

#### ► ANALOG OUTPUT

AIC . . . Isolated 16 Bit Current Output, 0-20mA and 4-20mA, pls. specify  
 AIV . . . Isolated 16 Bit Voltage Output, 0-10VDC

#### ► RELAY OUTPUT

Note: R1 and R2 are located on the main board, and are generally used when only two Form A Relays or less are required and an Analogy Output is not required.

R1 . . . Single 5A Form A Relay  
 R2 . . . Dual 5A Form A Relays

#### ► RELAY OUTPUT MODULES

Note: If a meter is ordered with a Relay Output Module, but without Analog Output, an Output Module Carrier Board should be automatically added to the order.

OR11 . . . One 10 Amp Form C Relay, Isolated  
 OR15 . . . One 10 Amp Form C and Two 5 Amps Form A Relays  
 OR16 . . . One 10 Amp Form C and One 5 Amp Form A Relays  
 OR12 . . . Two 10 Amp Form C Relays, Isolated  
 OR14 . . . Two 10 Amp Form C and Two 5 Amps Form A Relays  
 OR23 . . . Two 10 Amp Form C and One 5 Amp Form A Relay, Isolated  
 OR31 . . . One 5 Amp Form A Relay, Isolated  
 OR32 . . . Two 5 Amp Form A Relays, Isolated  
 OR33 . . . Three 5 Amp Form A Relays, Isolated  
 OR34 . . . Four 5 Amp Form A Relays, Isolated

#### Solid State Relay (SSR) Output Modules DC Only

OR51 . . . One 400V DC Solid State Relay (SSR) 210mA  
 OR52 . . . Two 400V DC Solid State Relays (SSR) 210mA  
 OR53 . . . Three 400V DC Solid State Relays (SSR) 210mA  
 OR54 . . . Four 400V DC Solid State Relays (SSR) 210mA

#### Solid State Relay (SSR) Output Modules AC/DC

OR61 . . . One 400V AC/DC Solid State Relay (SSR) 140mA  
 OR62 . . . Two 400V AC/DC Solid State Relays (SSR) 140mA  
 OR63 . . . Three 400V AC/DC Solid State Relays (SSR) 140mA  
 OR64 . . . Four 400V AC/DC Solid State Relays (SSR) 140mA

### Special Options and Accessories (OA's)

#### Part Number

#### Description

#### ► SPECIAL OPTIONS (Specify Inputs or Outputs & Req. Reading) Output Module Carrier Board

\*One carrier board must be ordered with any meter that includes any one or more of the following options: Analog Output and/or Relay Output Modules.

SA-DL/OM-CB . . . . Output Module Carrier Board, DL series  
 CR-CHANGE . . . . Range Change from Standard Range shown in BOLD type  
 CS-3/3.5/4 . . . . Custom display scaling within standard ranges  
 COA-3/3.5/4 . . . . Custom scaling of analog output for digital meters & bargraphs  
 CCL-SETUP . . . . NRC to set-up Custom Configuration file and issue serial #  
 CCL-INSTL . . . . Installation of custom configuration, specify serial #  
 CSR-SETUP . . . . NRC to set-up custom selectable range  
 CSR-INSTL . . . . Factory installation - custom configuration, specify serial #  
 CSS-SETUP . . . . NRC to set-up custom special scaling  
 CSS-34/INSTL . . . . Installation - for 3.5 and 4.0 meters, specify serial #  
 COR-SETUP . . . . NRC to set-up Relays in non-standard locations  
 COR-INSTL . . . . Installation - Relays in non-standard locations , specify serial #

#### ► ACCESSORIES (Specify Serial # for Custom Artwork Installation)

75-DBBZ9648F . . . . Black Bezel for 96x48mm Case  
 75-DMTCLIPF . . . . Side Slide Brackets (2 pc) - extra set, extra strength  
 76-DL40G-N4 . . . . "Touch" Green LED Faceplate, NEMA 4, Factory install  
 76-DL40LG-N4 . . . . "Touch" Large Green LED Faceplate, NEMA 4, Factory install  
 76-DL40LR-N4 . . . . "Touch" Large Red LED Faceplate, NEMA 4, Factory install  
 76-DL40R-N4 . . . . "Touch" Red LED Faceplate, NEMA 4, Factory install  
 ART-FS-S/D/C . . . . NRC for artwork & set-up Faceplate/Desc/Co.Logo  
 ART-FS-S/D . . . . NRC for artwork & set-up Faceplate/Desc  
 ART-FS-001 . . . . Install Custom Faceplate per meter - 1 color  
 OP-MTLCLIP . . . . Screw Mounting Clips (2 pc) - to screw tighten slide brackets  
 OP-MTL96X48 . . . . Metal Surround Case, includes screw mounting clips  
 OP-N4X/96X48 . . . . 96x48mm clear lockable front cover-NEMA 4X, splash proof

Prices subject to change without notice.

### WARRANTY

Texmate warrants that its products are free from defects in material and workmanship under normal use and service for a period of one year from date of shipment. Texmate's obligations under this warranty are limited to replacement or repair, at its option, at its factory, of any of the products which shall, within the applicable period after shipment, be returned to Texmate's facility, transportation charges pre-paid, and which are, after examination, disclosed to the satisfaction of Texmate to be thus defective. The warranty shall not apply to any equipment which shall have been repaired or altered, except by Texmate, or which shall have been subjected to misuse, negligence, or accident. In no case shall Texmate's liability exceed the original purchase price. The aforementioned provisions do not extend the original warranty period of any product which has been either repaired or replaced by Texmate.

### USER'S RESPONSIBILITY

We are pleased to offer suggestions on the use of our various products either by way of printed matter or through direct contact with our sales/application engineering staff. However, since we have no control over the use of our products once they are shipped, NO WARRANTY WHETHER OF MERCHANTABILITY, FITNESS FOR PURPOSE, OR OTHERWISE is made beyond the repair, replacement, or refund of purchase price at the sole discretion of Texmate. Users shall determine the suitability of the product for the intended application before using, and the users assume all risk and liability whatsoever in connection therewith, regardless of any of our suggestions or statements as to application or construction. In no event shall Texmate's liability, in law or otherwise, be in excess of the purchase price of the product.

Texmate cannot assume responsibility for any circuitry described. No circuit patent or software licenses are implied. Texmate reserves the right to change circuitry, operating software, specifications, and prices without notice at any time.



995 Park Center Drive • Vista, CA 92081-8397

Tel: 1-760-598-9899 • USA 1-800-839-6283 • That's 1-800-TEXMATE

Fax: 1-760-598-9828 • Email: sales@texmate.com • Web: www.texmate.com

Texmate has facilities in Japan, New Zealand, Taiwan, and Thailand. We also have authorized distributors throughout the USA and in 28 other countries.

For product details visit [www.texmate.com](http://www.texmate.com)

Local Distributor Address